

# Pinces de serrage poussées

Série 1

Type F

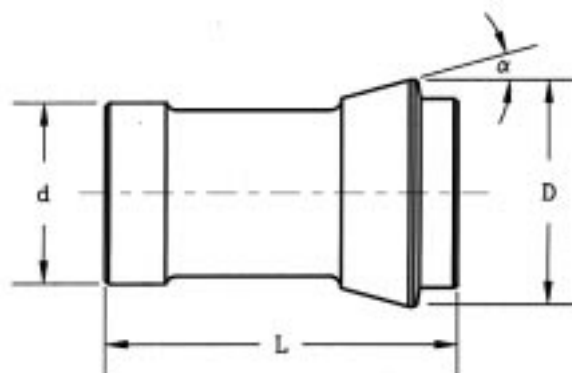

Référence	d	D	L	Cône α	Alésages		
					de - à ( mm )		par ( mm )
1008 E	4.5	6.75	17.25	15°	0.5 - 0.9	rond	0.1
					1.0 - 2.9	rond	0.1
					3.0	rond	.
1020 E	7	10.5	26	15°	1.0 - 1.9	rond	0.1
					2.0 - 2.9	rond	0.1
					3.0 - 5.5	rond	0.5
					3.1 - 5.4	rond	0.1
101 E	8	12	42	16°	0.5 - 0.9	rond	0.1
					1.0 - 2.9	rond	0.1
					3.0 - 6.0	rond	0.1
109 E	10	15.5	47.5	20°	0.5 - 0.9	rond	0.1
					1.0 - 2.9	rond	0.1
					3.0 - 7.0	rond	0.1
					4.0 - 6.0	6&4pans	1.0
					4.5 - 5.5	6&4pans	1.0
					2.0 - 3.0	6&4pans	1.0
1155 E	12	18.1	44.5	15°	1.0 - 2.9	rond	0.1
					3.0 - 3.9	rond	0.1
					4.0 - 10.0	rond	0.5
					4.1 - 9.9	rond	0.1
117 E	14	18	46	13°	0.5 - 0.9	rond	0.1
					1.0 - 1.9	rond	0.1
					2.0 - 2.9	rond	0.1
					3.0 - 10.0	rond	0.1
					10.1 - 11.5	rond	0.1
					4.0 - 6.0	6&4pans	1.0
					7.0 - 9.0	6&4pans	1.0
					4.5 - 7.5	6&4pans	1.0
120 E	15	21	64	16°	1.0 - 1.9	rond	0.1
					2.0 - 2.9	rond	0.1
					3.0 - 12.0	rond	0.1
					4.0 - 6.0	4 pans	1.0
					4.0 - 8.0	6 pans	1.0
					4.5 - 6.5	6&4pans	1.0
123 E	16	22	55	15°	2.0 - 2.5	rond	0.5
					3.0 - 13.0	rond	0.5
					3.1 - 9.9	rond	0.1
					4.0 - 10.0	6&4pans	1.0
					4.5 - 6.5	6&4pans	1.0

# Pinces de serrage poussées



Série 1

Type F

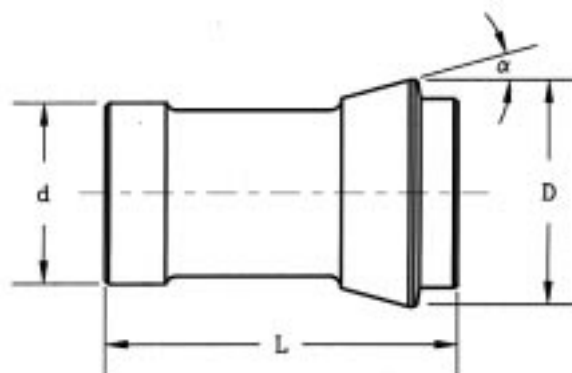

Référence	d	D	L	Cône $\alpha$	Alésages		
					de - à ( mm )	par ( mm )	
1299 E	20	27.5	60	15°	4.0 - 16.0 7.0 - 14.0	rond 6&4pans	1.0 1.0
136 E	20	26	54	15°	1.0 1.5 - 2.5 3.0 - 16.0 7.0 - 14.0	rond rond rond 6&4pans	. 0.5 0.5 1.0
138 E	20	28	67	16°	2.0 - 2.5 3.0 - 16.0 5.0 - 14.0	rond rond 6&4pans	0.5 0.5 1.0
140 E	22	30	55	15°	1.5 - 2.5 3.0 - 16.0 7.0 - 14.0 7.0 - 10.0	rond rond 6 pans 4 pans	0.5 0.5 1.0 1.0
1341 E	23	31	47	15°	3.0 - 20.0	rond	1.0
144 E	25	34	65	15°	6.0 - 20.0 8.0 - 17.0 8.0 - 14.0	rond 6 pans 4 pans	0.5 1.0 1.0
145 E	25	35	77	16°	3.0 - 20.0 8.0 - 14.0 8.0 - 14.0	rond 6 pans 4 pans	0.5 1.0 1.0
146 E	26	32	67	13°	5.0 - 20.0 8.0 - 17.0 8.0 - 14.0	rond 6 pans 4 pans	0.5 1.0 1.0
147 E	27	38	72.7	15°	1.0 - 1.5 2.0 - 2.5 3.0 - 23.0 7.0 - 19.0 7.0 - 16.0	rond rond rond 6 pans 4 pans	0.5 0.5 0.5 1.0 1.0
148 E	28	38	70	15°	2.0 - 2.5 3.0 - 24.0 7.0 - 19.0 7.0 - 14.0	rond rond 6 pans 4 pans	0.5 0.5 1.0 1.0
1446 E	30	38	65	15°	3.0 - 25.0 7.0 - 21.0	rond 6&4pans	0.5 1.0
157 E	30	42	80	16°	3.0 - 25.0 7.0 - 22.0 7.0 - 14.0	rond 6 pans 4 pans	0.5 1.0 1.0

# Pinces de serrage poussées



Série 1

Type F

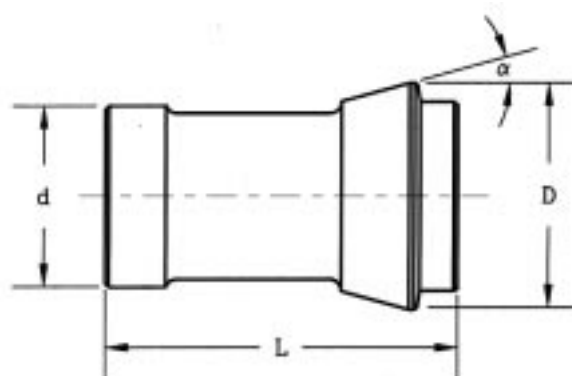

Référence	d	D	L	Cône $\alpha$	Alésages		
					de - à ( mm )		par ( mm )
161 E	32	45	75	15°	3.0 - 26.0	rond	0.5
					7.0 - 22.0	6 pans	1.0
					7.0 - 14.0	4 pans	1.0
163 E	35	48	80	15°	2.0 - 2.5	rond	0.5
					3.0 - 30.0	rond	0.5
					7.0 - 27.0	6 pans	1.0
					7.0 - 14.0	4 pans	1.0
1536 E	37	47	92	16°	4.0 - 32.0	rond	0.5
					10.0 - 26.0	6 pans	1.0
164 E	38.1	49	107.5	15°	3.0 - 32.0	rond	0.5
					6.0 - 27.0	6 pans	1.0
					6.0 - 22.0	4 pans	1.0
173 E	48	60	94	15°	3.0 - 42.0	rond	0.5
					7.0 - 27.0	6 pans	1.0
					28.0 - 36.0	6 pans	1.0
					10.0 - 22.0	4 pans	1.0
					23.0 - 28.0	4 pans	1.0
185 E	66	84	110	15°	4.0 - 60.0	rond	1.0
					8.0 - 27.0	6 pans	1.0
					28.0 - 36.0	6 pans	1.0
					37.0 - 50.0	6 pans	1.0
					51.0 - 52.0	6 pans	1.0
					7.0 - 22.0	4 pans	1.0
					23.0 - 28.0	4 pans	1.0
					29.0 - 42.0	4 pans	1.0
1791 E	68	84	109	15°	25.0 - 61.0	rond	1.0
					20.0 - 32.0	6 pans	1.0
					33.0 - 40.0	6 pans	1.0
					41.0 - 50.0	6 pans	1.0
					51.0 - 52.0	6 pans	1.0
					20.0 - 32.0	4 pans	1.0
					33.0 - 40.0	4 pans	1.0
					41.0 - 42.0	4 pans	1.0